

SHOEBOX ELECTRONIX 8691V ECU MONITOR



USER MANUAL & TROUBLESHOOTING GUIDE

Oct 6, 2008

Your Vanagon & it's ECU

It is important for the ECU Monitor System to work for you effectively, that your engine be tuned to it's best possible running condition. Spark plugs, spark plug wires, rotor cap, and distributor rotor should first be replaced. and all basic engine adjustments (timing, etc) verified. It is also probably a good idea to check or simply replace either one or both of your fuel filters, depending which fuel filter system you have (one or two filters). We are assuming in this case, that the problem is intermittent, or at temperature, and that your engine is able to be tuned and will run. If your problem is an inability to start the engine cold, then proceed to page 19 in TROUBLESHOOTING to rectify this problem first.

1986 through 1991 Vanagons all utilize the Bosch (or Bosch equivalent) Engine Control Unit, or as we will refer to it, ECU, to electronically enable the fuel pump, and control the fuel injection pulses and ignition timing of your engine. These outputs are modified by the ECU according to the state or level of their respective inputs.

Vanagon ECU & Associated Subsystems

The ECU is but one component, albeit an important one, in the Vanagon 2.1 Liter engine. The ECU collects sensor information, and controls other units in the engine system. While the ECU is like the quarterback, all the players must contribute efficiently to make the team run smoothly. The basic requirements for an internal combustion engine to operate are fuel, spark, and air. The modern engine utilizes electronic technology to constantly monitor and control the critical engine variables.

This drawing shows the relationship of the ECU to the other components of your engine that connect to it. Remember that your Vanagon may not have the Fuel Filter installed. There are both versions out there in the real world.

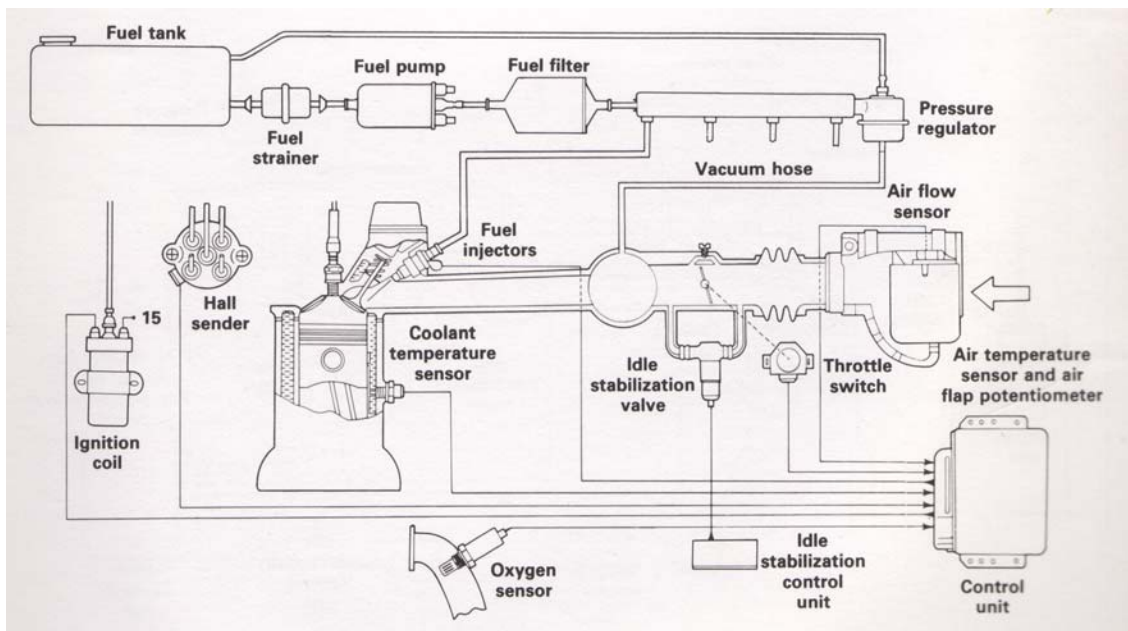

So, the Bosch ECU computer does a lot of work, but it is not rocket science by any means. The Bosch ECU is a relatively simple signal converter and interface, which does the work of previously separate external sub-systems (e.g. the old mechanical choke has been replaced by the fuel injector pulse width (wider pulse = more gas)). Once you understand what it does, it is easier to understand problems associated with it.

ECU Input Signals

The ECU relies upon its input signals to allow it to decide what to tell your engine. As your engine temperature increases as it warms up, the ECU will continuously adjust the timing and injector pulses accordingly. As you drive, the ECU senses changes from the air flow meter to determine the load on your engine and modifies those signals. The same goes for the oxygen sensor, air temperature, and Hall sensor signals. The old computer rule, "GIGO" (garbage in, garbage out) applies here. If any of the input signals is incorrect or intermittent, the ECU control signals out will also be incorrect or intermittent. Normally, bad sensors cause bad inputs. It is possible that your ECU is at fault, but more common that a sensor input is causing you grief.

ECU INPUT SIGNAL	SOURCE
Coolant Temperature	Coolant Temperature Sensor by thermostat
Air Temperature	Air Temperature Sensor in air flow meter
Battery Voltage	12V B+ engine wiring harness
Distributor Timing Pulses	Hall sensor mounted on distributor
Oxygen Sensor Voltage	O2 sensor on catalytic converter
Air Flow Meter Volume	Air flow meter potentiometer
Throttle Position	Throttle position switch

ECU Output Signals

Based upon the signals supplied to the ECU, the ECU in turn provides output signals to allow proper engine operation:

ECU OUTPUT SIGNAL	DESTINATION
Fuel Injector Pulses	Fuel Injector Solenoids
Ignition Pulses	Ignition Coil

Observing Signals on the ECU Monitor

Power Up ECU Monitor

Position the 9' long gray ribbon cable between the front seats. Pull the cable gently until you have some slack at your end. The blue cable connector on the ribbon cable connects the ECU to the ECU Monitor. First make sure the power switch is OFF (down). Then, simply orient the blue connector with the ribbon cable red stripe to the left, and the cable as shown, and insert the cable connector into the front panel jack. The connector should go into place easily.

Place the Monitor in a convenient viewing location (we like the passenger seat, but if you are carrying a passenger who refuses to ride in the back seat, you can place it on the floor between the front seats (best for viewing in bright sunlight). Position the ECU Monitor power switch in the ON (up) position as shown. Rotate the selector switch CW with the knob indicator pointing down towards the power switch. Turn your ignition key to the first (ACC) position. You should observe the red indicators illuminate on your instrument panel. Your ECU monitor should display as follows: THROTTLE POSITION = ON, FUEL INJ PULSE = ON, BATTERY VOLTAGE = ON, and the digital display will indicate your vehicle battery voltage (for example, 12.08V):



Displaying Sensor Voltages

Gentlemen, start your engine. The START RUN indicator will illuminate while you have your starter engaged, and then go out once your engine is running. The THR POS SWITCH & FUEL PUMP indicators should be lit, and the FUEL INJ PULSE, HALL PULSE, and COIL PULSE indicators should be pulsing. Normal alternator activity is indicated by a battery voltage displayed that is greater than with the engine off; in our case 13.71V.

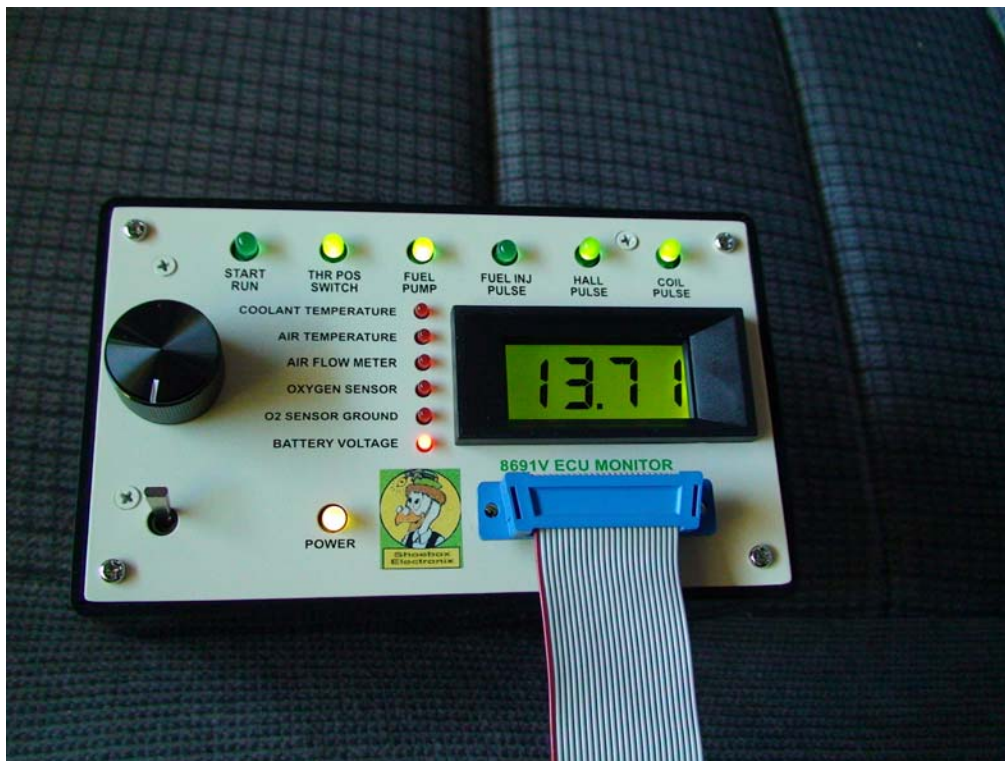

Now rotate the selector switch to the full CCW position, COOLANT TEMPERATURE. This should illuminate the red coolant temperature indicator, and the digital display will indicate a voltage representative of the coolant temperature sensor temperature. In our case, with an outside temperature of approximately 65 deg F, our voltage displayed was 0.42V. Yours can and will probably be different. This value will depend on the coolant temperature at the time.

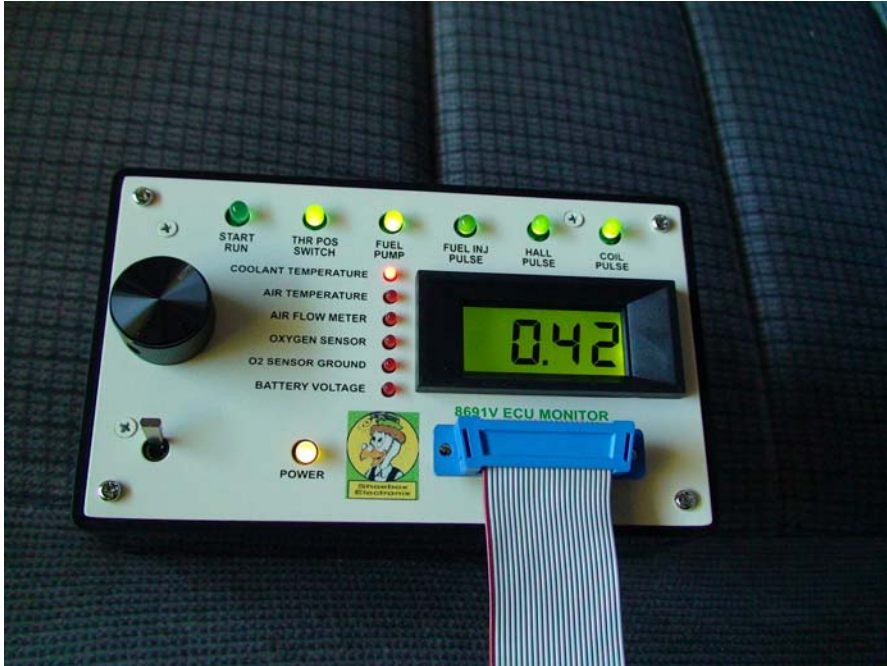

Digital Panel Meter

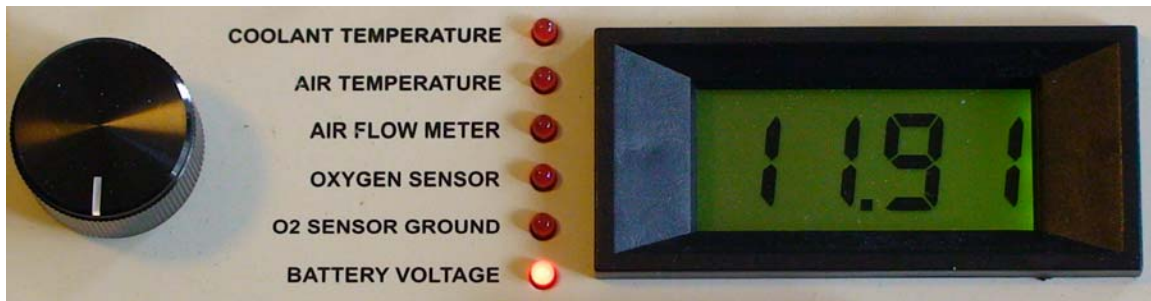

You can display the different sensor voltages by rotating the selector switch to the desired position. The approximate values are as follows:

SENSOR	COLD (key on)	WARM IDLE	30 MPH	60MPH
COOLANT TEMPERATURE	<.95V	0.17V	0.18V	0.21V
AIR TEMPERATURE	1.15V	1.10V	1.00V	1.00V
AIR FLOW METER	0.25V	1.70V	3.00V	3.90V
O2 SENSOR	0.65V	0.2 to 0.9V *	0.2-0.9V	0.2-0.9V
O2 SENSOR GROUND	0 V (APPROX)	0V	0V	0V
BATTERY VOLTAGE	12.0V	13.50V	13.50V	13.50V

Keep in mind as you use this system, that exact sensor voltage values are normally not as important as the linearity and presence of the signal. As an example, your coolant temperature might indicate .15V at temperature, but appears linear between cold and hot, and the display is steady. A bad temperature sensor will normally be either very far from a normal value, but also and more importantly, display an erratic value either all the time or intermittently. This might be a display varying between .3 and 2.5V with or without accompanying engine miss.

Take your Vanagon out for a drive, observing (SAFELY) the sensor voltages displayed on the digital meter. You will quickly see the sensor values change as engine temperature, RPM, and outside air temperatures change. * The oxygen sensor reading will display relatively steady at first (approx .7V) but after warm up, with your engine at temperature, it will be constantly correcting the feedback signal to the ECU to stay in synch with the amount of fuel in your catalytic converter. The normal search range is approximately 0.2 - 0.9V.

Monitor Status Indicators

The Monitor Status Indicators are located above the digital meter.



START RUN

The START/RUN indicator should be ON when you first turn your key to the START position of the ignition switch, and remain OFF during normal engine operation. It represents the starter being energized. If you do not see this indicator illuminated when you start your engine, chances are your engine will not start. You will need to troubleshoot the reason for this before you go any further.

THROTTLE POSITION SWITCH

This indicator provides an indication of the position of the throttle – either fully closed, indicator ON, or fully open, indicator ON. If you see this indicator do anything else, like going into the ON state while you are at anything but idle or full throttle, there is a problem with your throttle position switch.

FUEL PUMP

Indicates 12VDC being provided to the fuel pump. Once again, this signal is necessary for your fuel pump to provide fuel to your engine. Any variation, and your engine will either not run, or will run intermittently. The fuel pump relay is a good place to start troubleshooting this type of problem.

FUEL INJECTOR PULSE

The fuel injector pulse indicator represents the pulses sent to the fuel injector solenoids. This pulse signal should be present whenever the engine is running. The indicator brightness will vary with the engine RPM – lower RPM, more apparent blinking, Higher RPM, appears almost steady brightness.

HALL PULSE

Represents the pulse from the distributor to the ECU, providing the ECU with engine RPM and timing information.

COIL PULSE

Represents the ignition pulse provided to the electronic ignition from the ECU, with timing adjusted for temperature, engine load, and RPM. Both the coil pulse and the hall pulse are necessary for the engine to run.

Digifant System Components

Electronic Control Unit (or ECU)

The Digifant electronic control unit incorporates all the functions of the fuel system and ignition system and provides both the actuation signal for the fuel injectors and optimum ignition timing point for all engine operating conditions.

Injection duration opening signals are provided based on the following inputs:

- Engine speed
- Intake air volume
- Coolant temperature
- Oxygen content in the exhaust gas
- Battery voltage
- Intake air temperature

The injector opening time is taken from a program in the control unit at 16 points for RPM, and 16 points for load, for a total of 256 operational points. Injection times can be determined between these fixed points for a total of 65,000 theoretical different opening points.

Coolant Temperature Sensor

The coolant temperature sensor is a negative temperature coefficient resistor (NTC). The voltage signal it produces is used by the control unit to determine:

- The amount of cold-start and warm-up enrichment
- Ignition timing and idle stabilization during warm-up
- When the oxygen sensor, idle stabilization, and full-throttle enrichment functions are activated.

Fuel Pump

The fuel pump is a roller cell design. It is driven by a permanent magnet electric motor and is located near the fuel tank. Steel rollers are held in “cut-outs” on the rotor. Centrifugal force seals the rollers against the walls of the pressure chamber as the rotor spins. Fuel is trapped between the rollers and is forced out the delivery port. The pump is designed to be both cooled and lubricated by the fuel flowing through it. The pump delivers several times the amount of fuel needed to operate the engine at any time. Excess fuel is returned to the fuel tank via the fuel pressure regulator.

Fuel Pressure Regulator

The system pressure regulator maintains a constant fuel pressure to all injectors by regulating the quantity of fuel returned to the fuel tank. The regulator is connected to the intake manifold. It responds to intake manifold vacuum fluctuations, thereby compensating for changes in engine load.

Fuel Injectors

Digital fuel injectors are electronically controlled on/off valves. A solenoid actuates a needle valve allowing fuel to be forced through the injector nozzle. All four injectors open at the same time and inject fuel directly into the intake manifold near the intake valves. Injector quantity is controlled by the amount of time the solenoids are energized. This in turn is controlled by the fuel injector pulse width, determined by the ECU.

Note: Digital injectors (yellow body) are NOT interchangeable with AFC (blue body) injectors.

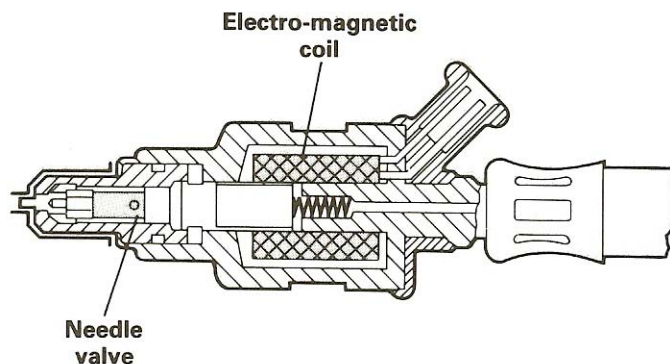

Air Flow Sensor

The airflow sensor measures the amount of air entering the intake manifold and sends a voltage signal representing this amount to the ECU. Intake air opens the airflow sensor flap, which actuates the potentiometer to determine the voltage level. This signal and the engine speed information provided by the Hall sender are used as the principal inputs for the determination of fuel injection opening duration and ignition timing points. A compensation flap connected to the air sensor dampens sudden movements of the air sensor flap due to oscillations of the intake air.

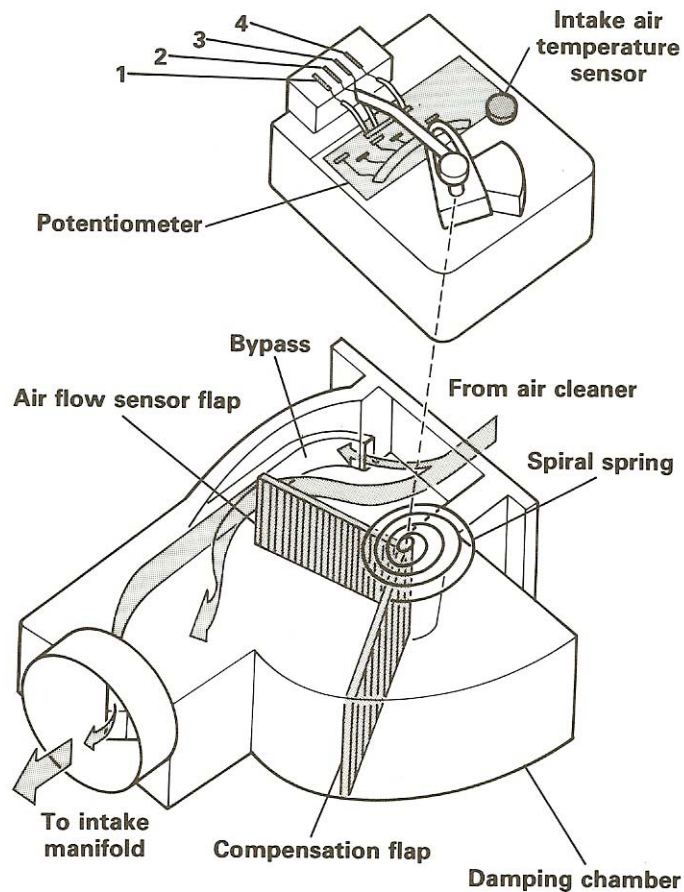

Intake Air Temperature Sensor

An intake air temperature sensor is located in the airflow sensor housing. It is a negative temperature coefficient (NTC) resistor, which means its resistance value drops as the temperature increases. The signal it supplies to the ECU is used to modify fuel injection rate depending on intake air temperature.

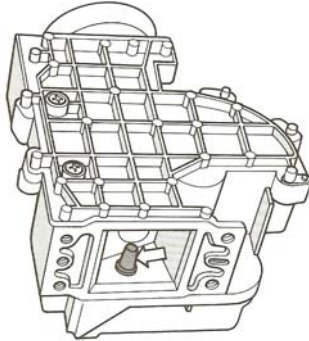

Throttle Position Switch

Digifant uses a single throttle position switch to signal the ECU when the throttle plate is fully closed (idle), or fully open (full load) position. This signal enables the ECU to determine that one of three auxiliary functions (idle stabilization, deceleration fuel shut-off, or full load enrichment) is required and then activate the appropriate circuit. The throttle position switch is a normally open switch. A cam activates the contact arm with two eccentrics, attached to the throttle plate shaft. One eccentric closes the contacts in the fully closed position and the other in the fully open position. Correct adjustment is very important. If misadjusted, the engine may surge at idle, or cut out during steady driving or light acceleration.

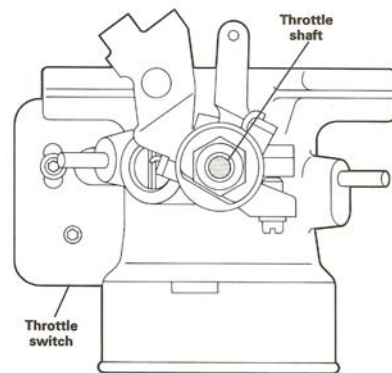

Fuel Filters

Your Vanagon may have either a single or dual fuel filter system. Two types are used on the Digifant system. One is a square plastic fuel strainer, which is mounted in front of the fuel pump to protect it from foreign particles. The other fuel filter is a metal cylinder, which mounts behind the fuel pump. It has a finer filtering mesh to protect the fuel injection components. According to VW, both are lifetime filters, and do not normally need replacement, however, we suggest that the filters be changed every 60K-100K miles.

Ignition System

The map controlled ignition system operates on the principle of a timing map, which is programmed into the ECU. Information on engine load, speed, and coolant temperature are provided to the ECU in the form of voltage signals. These signals are processed by the ECU so that the ignition coil is controlled via terminal #1 in accordance with the programmed ignition map. The separate ignition control unit and digital idle stabilizer used in the past have been eliminated. An engine speed signal is transmitted from the Hall sender in the distributor, and engine load measurement is accomplished through the signal from the air flow meter potentiometer. These two signals establish the ignition timing point. The engine coolant temperature sensor signals the ECU to determine ignition timing based on engine temperature. The engine's ignition timing is constantly being corrected throughout the engine warm-up phase. Once the engine is warmed up, the internal timing map in the ECU determines the ignition timing.

Oxygen Sensor

The oxygen sensor is made of a ceramic material called Zirconium Dioxide. The inner and outer surfaces of the ceramic material are coated with platinum. The outer platinum surface is exposed to the exhaust gas, while the inner surface is exposed to the outside air. The difference in the amount of oxygen contacting the inner and outer surfaces creates a pressure differential, which results in a small voltage signal in the range of 175 – 1,100 millivolts (0.175 – 1.10 volts) supplied to the ECU. The fuel mixture determines the amount of voltage produced.

Oxygen Sensor (cont)

A higher voltage indicates a rich mixture, and a lower voltage indicates a lean mixture. The sensor is electrically heated to keep it at a constant operating temperature. This insures continuous and accurate reaction of the sensor during all operating conditions. The oxygen sensor should be replaced every 60,000 miles. If your oxygen sensor is beyond this limit, or if you are not sure, order a Bosch generic replacement from Volks Café. The factory version is four or five times as expensive.

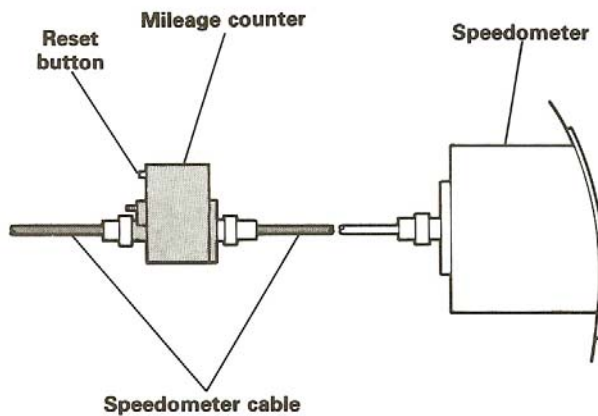
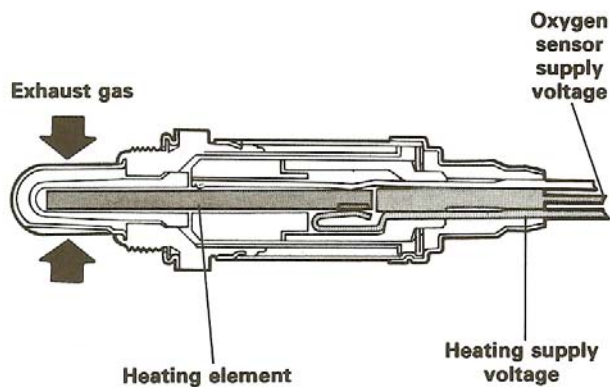

Idle Stabilization System

The idle stabilization system used on the Digifant system ensures the idle speed remains constant at pre-determined levels. The system controls the amount of air bypassing the throttle plate. If engine idle speed varies from the value stored in the ECU, the idle stabilizer valve will adjust the volume of air entering the engine at idle. This maintains idle speed within preset limits. A control unit located in the engine compartment near the air cleaner intake hose operates the idle stabilizer valve. The control unit receives inputs from the following components:

- Throttle Position Switch
- Coolant Temperature Sensor
- A/C Compressor Clutch
- Ignition Coil Terminal #1
- Automatic Transmission Selector Switch (if applicable)
- Power Steering Pressure Switch

With this system, the auxiliary air regulator and digital idle stabilizer have been eliminated, and any periodic idle adjustment is no longer required.

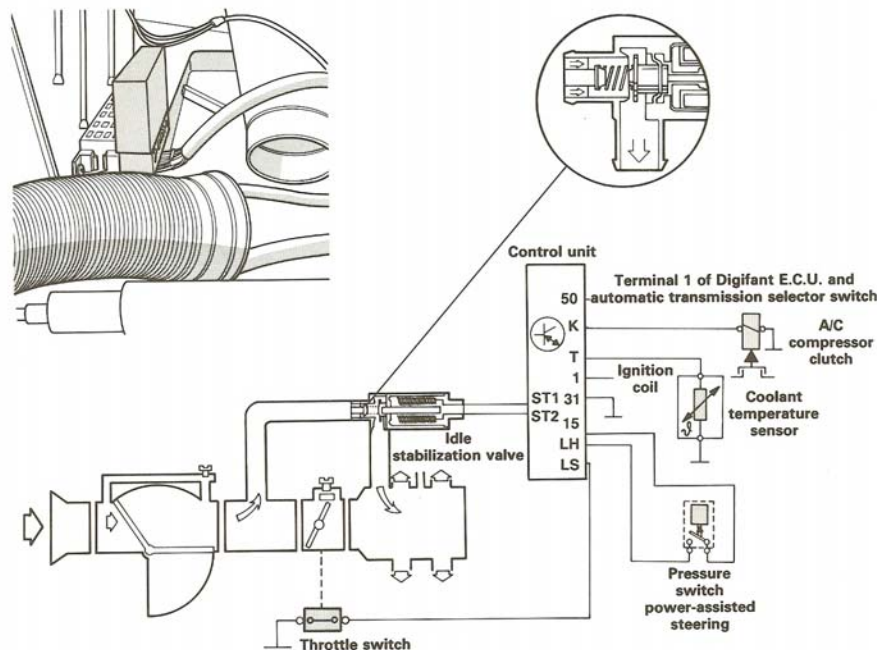

Troubleshooting

Basics

It is important to keep in mind as you are using this System as a troubleshooting tool, the monitor and ECU simply allow the user to monitor input and output signals at the ECU, that would normally be difficult to reach with a voltmeter probe, especially while running the engine or driving the vehicle. In my case, I had two separate problem components, causing two different symptoms. My coolant temperature sensor was intermittent, causing the engine to try to run very rich, which not only wasted gasoline, but also caused the engine to hesitate badly, and almost stop running at highway speeds. The second problem was a bad oxygen sensor, causing the engine to be very, very difficult to start after it was hot. Simply watching the digital display and dialing it to different sensor inputs will make identifying intermittent and out of range sensor inputs a breeze.

Troubleshooting Guidelines

Keep in mind these guidelines are provided to associate problem areas with systems that are known causes. This is not to say that a bad ECU cannot cause poor gas mileage, it can, but the probability is low. Also, keep the basics in mind as you troubleshoot – start by visually inspecting everything relating to your problem twice or even three times. A broken wire making intermittent contact, or something similar causes many strange problems. Even electrical problems sometimes yield visual clues – burnt or arc marks, spark plug wire holes, or the like.

Remember also, that components that are in the toughest environments are the most likely suspects to fail sooner. Example – the coolant temperature sensor is under more temperature stress than the air temperature sensor, and therefore more likely to fail. In a similar fashion, the input side of your ignition system takes less of a beating than the output side (lower voltage versus higher voltage).

- **Engine will not start, hot or cold**
 - a. No Fuel
 - Fuel System
 - Injector System
 - Air Flow Sensor
 - b. No spark
 - Ignition System

- **Engine will not start hot**
 - Oxygen Sensor
 - Coolant Temperature Sensor
 - Hall Sender (in distributor)

- **Hard starting, hot or cold**
 - a. No fuel or excessive fuel
 - Coolant temperature sensor
 - Fuel System
 - Evaporative Emission System
 - b. No spark
 - Ignition System

- **Poor Idle**
 - a. At operating temperature
 - Throttle Position Switch
 - Idle Stabilizer System
 - Evaporative Emission System
 - b. Cold engine
 - Coolant Temperature Sensor
 - Idle Stabilization System

- **Engine stalls at highway speeds**
 - Coolant Temperature Sensor
 - Fuel system
 - Ground and terminal connections

- **Poor Performance**
 - a. During warm-up
 - ___ Coolant Temperature Sensor
 - ___ Throttle Position Switch
 - ___ Idle Stabilizer System
 - b. At Operating Temperature
 - ___ Throttle Position Switch
 - ___ Ignition System
 - ___ Fuel System
 - ___ Idle Stabilizer System
 - c. At Full Throttle
 - ___ Throttle Position Switch
 - ___ Ignition System
 - ___ Fuel System
- **High Fuel Consumption**
 - ___ Throttle Position Switch
 - ___ Fuel System (leakage, spray pattern)
 - ___ Evaporative Emissions System (leakage)
 - ___ Oxygen Sensor (these only last 60K-100K miles)

Addendum

Electrical Wiring

There is not enough room to reproduce the various electrical wiring diagrams that might apply to your particular Vanagon. Our preferred reference book for this, and a lot of other technical information on Vanagons, is the Bentley Green Book that covers your year vehicle. In addition to complete engine tear down and rebuilding, the book is divided into several chapters covering all subsystems from brakes to fuel. The wiring references in this document refer to the wiring diagrams on pages 97.201 – 97.233, in the 1980-1991 Vanagon edition ISBN 0-8376-0336-6.

Since you own a Vanagon, you should own one of these books. It is a Factory Service Manual of the highest quality. The Bentley Book is available to order online at www.van-cafe.com

Website

Also, be sure to visit our website at www.shoebox-electronix.com You will not only find all our product documentation, but also a collection of technical and troubleshooting files in pdf format that include both the Digijet and Digifant ECU systems, links to useful Vanagon websites, and information about both current and future Shoebox Electronix products.

Hopefully this manual has provided you with information and guidance in helping you understand the operation of your ECU Monitor and also in troubleshooting your ECU and some of its associated systems.

Thanks once again for your support. Please feel free to contact us with any questions or suggestions at:

Shoebox Electronix
4805e Grace Street
Capitola CA 95010
831-462-5530